

Standby or Prime Power Features

- Heavy-duty industrial diesel engine
- Brushless synchronous alternators: four-pole construction, dynamically balanced
- Full featured microprocessor based controller: fully programmable for maximum flexibility
- Prototype tested and production tested
- Gen-set accepts rated load in one step
- UL2200 available – consult factory
- Optional weather-proof and sound attenuated enclosures available
- Full range of accessories and options available
- Heavy-duty construction for use in prime or standby application
- Manufactured in an ISO-9001 certified facility
- Backed by a world wide network of parts and service center

Gen Set Ratings

| Baldor Genset Model | kW Rating Standby | kW Rating Prime | Voltage Hi-Wye | Voltage Low-Wye | Voltage Delta | Number of Leads | Phase | Hz | Power Factor |
|---------------------|-------------------|-----------------|----------------|-----------------|---------------|-----------------|-------|----|--------------|
| IDLC600-MA | 600 | 550 | 480/277 | 240/139 | N/A | 12 | 3 | 60 | 0.8 |
| IDLC600-MA | 600 | 550 | 440/254 | 220/127 | N/A | 12 | 3 | 60 | 0.8 |
| IDLC600-MB | 600 | 550 | 416/240 | 208/120 | 240/120 | 12 | 3 | 60 | 0.8 |
| IDLC600-MC | 600 | 550 | 380/220 | N/A | N/A | 12 | 3 | 60 | 0.8 |
| IDLC600-MH | 600 | 550 | 600/347 | N/A | N/A | 12 | 3 | 60 | 0.8 |
| IDLC600-MXB | 530 | 475 | 380/220 | N/A | N/A | 12 | 3 | 50 | 0.8 |

NOTES: For ratings and voltages not listed above refer to the Gen-Set Selector or consult factory
 Standby ratings do not have an overload capability but can be used for the duration of the utility failure per ISO-3046, DIN6271 and BS5514
 Prime (Unlimited Running Time) ratings are continuous per DIN 6271 and ISO-3046 with 10% overload capacity
 Base Load (Continuous) ratings are continuous per DIN 6271, BS5514 and ISO-8528 with no sustained overload capacity
 Consult factory for Base Load ratings
 Altitude derate is 4% for each 1000 feet over 5000
 Temperature derate is 1% for 10°F over 100°F ambient

Controls Digital Control Module

MEC2 Features

- Large Backlit LCD with alpha-numeric readout
- Microprocessor Based Design
- 16 programmable alarms/shutdowns set points
- 4 programmable inputs
- Alarm horn
- Not in Automatic Alarm
- Digital Three Phase Voltage and Current Monitoring
- Password Protected Front Panel Programming
- 4 Programmable Outputs
- Local Emergency Stop Switch
- Optional NFPA110 Level I

Engine Protections

- Digital Oil Pressure Gauge
- Digital Water Temperature Gauge
- Digital Battery Voltmeter
- Overspeed Shutdown
- Emergency Stop Shutdown
- Loss of Speed Signal
- Overcrank Shutdown

Designed To Meet/Exceed the Standards Below:

- UL 508
- UL 2200
- NFPA 70
- NFPA 110

Engine Technical Data

| Hertz | 50Hz | 60 Hz | | |
|--|-----------------------------|-----------------------------|--------------------------|-------------------------|
| Manufacturer | Mitsubishi | Mitsubishi | | |
| Engine Model | S6R-Y1PTA-5 | S6R-Y1PTA-4 | | |
| Engine Type | 4 Cycle, Water Cooled | 4 Cycle, Water Cooled | | |
| Aspiration | Turbo-Charged, After Cooler | Turbo-Charged, After Cooler | | |
| No. of Cylinders & Configuration | 6, Inline | 6, Inline | | |
| Displacement - cu. in. - liters | 1496 (24.51) | 1496 (24.51) | | |
| Bore and Stroke - in. - mm | 6.69 X 7.09 (170 X 180) | 6.69 X 7.09 (170 X 180) | | |
| Compression Ratio | 15.0:1 | 15.0:1 | | |
| Air Filter Type | Dry | Dry | | |
| Governor Type | Electronic | Electronic | | |
| Governor Make | Woodward | Woodward | | |
| Governor Model | Woodward Pro-Act II | Woodward Pro-Act II | | |
| Frequency Regulation, steady state | +/- 0.25% | +/- 0.25% | | |
| Frequency Regulation, no load to full load | Isochronous | Isochronous | | |
| Battery Voltage | 24 VDC | 24 VDC | | |
| Water Pump Type | Centrifugal | Centrifugal | | |
| Coolant Cap. - radiator cooled - qts - liters | 161 / 152 | 161 / 152 | | |
| Coolant Capacity - engine only - gals - liters | 13.2/50 | 13.2/50 | | |
| Oil Pan Capacity - gals - liters | 13.2-21.1/50-80 | 13.2-21.1/50-80 | | |
| Rec'd Oil Type - SF/CC/CD-10°F to 90°F | 10W-40 | 10W-40 | | |
| Engine Operational Values | English 50 Hz | Metric 50 Hz | English 60 Hz | Metric 60 Hz |
| Maximum ambient temperature - F° - C° | 104/122 | 40/50 | 104/122 | 40/50 |
| Heat rejected to coolant - Btu/min - kWm | 20,733 | 364 | 24,838 | 436 |
| Max. power at rated rpm - bhp - kWm | 782 | 583 | 898 | 670 |
| Coolant flow - gpm - lpm | 177 | 670 | 211 | 800 |
| Exhaust temperature - F° - C° | 1000 | 538 | 973 | 523 |
| Exhaust flow - cfm - m ³ /min | 4,661 | 132 | 5,579 | 158 |
| Normal oil press. range idle/run - PSI - kgf/cm ² | 29-43/71-93 | 2-3/5-6.5 | 29-43/71-93 | 2-3/5-6.5 |
| Max fuel flow to injection pump - gph - Lph | 57 | 215 | 63 | 240 |

Gen Set Technical Data

Alternator Technical Data

| | | | | |
|---------------------|-------------------------|----------------------------|--------------------------------|----------|
| Generator Frame | 5 / 6 | Voltage Regulation NL - FL | +/- 1.0 % | +/- 0.5% |
| Exciter | Brushless | Underspeed Protection | Standard | |
| Cooling Fan | Cast alloy aluminum | Overexcitation Protection | Optional | Standard |
| Bearing | Single, double shielded | Overvoltage Protection | Optional | Standard |
| Connection Type | Reconnectable | Loss of Sensing Protection | Standard | |
| Insulation Type | Class H | Overspeed | 2250 RPM | |
| Windings | 100% copper | Standards | NEMA, IEC, IEEE, CSA, BS | |
| Pitch | 2/3 | Phase Sequence | A(U), B(V), C(W) | |
| Amortisseur Winding | Full | TIF (1960 Weightings) | <50 | |
| Voltage Regulator | SX440 MX321 | Excitation System | PMG - Optional / Std - 6 Frame | |

| Alternator Performance Data | Model IDLC600-MA | Model IDLC600-MB | Model IDLC600-MC | Model IDLC600-MH |
|--|---------------------|---------------------|---------------------|---------------------|
| Temperature rise by resistance - °C (Stand-By) | 150/40 | 150/40 | 150/40 | 150/40 |
| Generator model number | HCI544E | HCI544F | HCI634G | HCI544E |
| Generator kW at 125/105/80°C over 40°C ambient (480 Volt , 60Hz) | 600/540/475 | 660/600/528 | 800/730/632 | 600/540/475 |
| SkVA output with 30% voltage dip max. 100% recovery at 60 Hz | 1980 | 1920 | 2400 | 1980 |
| Maximum SkVA at 90% sustained voltage dip | Consult Baldor | Consult Baldor | Consult Baldor | Consult Baldor |
| Subtransient reactance at voltage listed | 10% | 9% | 18% | 10% |
| Line - line harmonic maximum total | 5.00% | 5.00% | 5.00% | 5.00% |

| Installation/Application Data | English 50 Hz | Metric 50 Hz | English 60 Hz | Metric 60 Hz |
|---|---|-----------------|------------------|-----------------|
| Ventilation requirements | | | | |
| a. Cooling airflow required - cfm - m ³ /min (unit mounted radiator) | 20,550 | 582 | 25,423 | 720 |
| b. Combustion air required - cfm - m ³ /min | 1,766 | 50 | 2,119 | 60 |
| Total ventilation requirements - cfm - m³/min (a. + b.) | 22,316 | 632 | 27,542 | 780 |
| Maximum cooling air restriction - in.H ₂ O - in.hg | 0.5 | 0.037 | 0.5 | 0.037 |
| Recommended minimum intake louver size (based on "free area") | 22.3 | 0.6 | 27.5 | 0.8 |
| a. Heat rejected to ambient, engine - Btu/min - kWm | 2,488 | 44 | 2,981 | 52 |
| b. Heat rejected to ambient, generator - Btu/min - kWm | 1,708 | 30 | 1,708 | 30 |
| Total heat rejection to ambient - Btu/min (a. + b.) | 4,196 | 74 | 4,689 | 82 |
| Exhaust system requirements | | | | |
| Exhaust gas flow - cfm - m ³ /min | 4,661 | 132 | 5,579 | 158 |
| Exhaust temperature (dry manifold) - °F - °C | 1000 | 538 | 973 | 523 |
| Maximum back pressure - in.H ₂ O - mm H ₂ O (inclusive of silencer) | 24 | 600 | 24 | 600 |
| Exhaust outlet size - in. - mm | 8 | 203 | 8 | 203 |
| Emissions - NO _x - g/BHP-hr - g/kW-hr | | | 6.30 | 8.50 |
| Emissions - HC - g/BHP-hr - g/kW-hr | Meets EPA Tier I Consult Baldor for values | | 0.52 | 0.70 |
| Emissions - CO - g/BHP-hr - g/kW-hr | | | 0.52 | 0.70 |
| Emissions - PM - g/BHP-hr - g/kW-hr | | | 0.14 | 0.19 |
| Fuel system requirements | | | | |
| Fuel consumption - 1/4 load - gph - Lph | 12 | 45 | 14 | 53 |
| Fuel consumption - 1/2 load - gph - Lph | 20 | 76 | 23 | 87 |
| Fuel consumption - 3/4 load - gph - Lph | 28 | 106 | 33 | 125 |
| Fuel consumption - Full load - gph - Lph | 37 | 140 | 45 | 170 |
| Heat Exchanger Cooling system requirements | | | | |
| Minimum raw water (city water) flow - gpm - lps | Consult Baldor | | Consult Baldor | |
| Maximum supply water temperature - °F - °C | | | | |
| Remote Cooling system requirements | | | | |
| Maximum coolant static head - ft. - m | Consult Baldor | | Consult Baldor | |
| Ventilation required (based on 25°F temp rise) - cfm - lps | | | | |

Accessories and Options

Control Panel

- Louver Relay – 10 Amp
- Run Relay – 10 Amp
- Dry Contacts For Alarms
- Remote E-Stop
- Control Panel Heater
- Tachometer
- Remote Annunciator
- Remote Communication
- Panel Lights w/Switch
- Generator Voltage Adjust
- Modem For Remote Communication

Engine Exhaust System

- Industrial Silencer
- Residential Silencer
- Critical Silencer
- Exhaust Flex
- Exhaust Extension
- Rain Cap
- _____

Generator Accessories

- Main Line Circuit Breaker
- Exciter Field Circuit Breaker
- Ground Fault Module w/Breaker Shunt Trip
- Ground Fault Module w/o Breaker Shunt Trip
- Reconnectable Link Bars
- Drip Cover IP22
- Manual Voltage Control
- Space Heater
- RTD's Stator Windings
- RTD's Bearing (Rear)
- PMG
- MVC300 Manual Voltage Control

Engine Electrical System

- Batteries
- Battery Rack
- Battery Cables
- Battery Charger - Automatic
- Battery Charger - Trickle
- _____

Engine Fuel System

- Day Tank
- Sub-Base Fuel Tank
- Storage Tank
- Flexible Fuel Lines
- _____

Miscellaneous

- Weather Proof Enclosure
- Sound Attenuated Enclosure
- Trailer Mounted
- Vibration Isolators
- Coolant Heater
- Oil Heater
- Bypass Oil Filter
- Export Crating

- _____
- _____
- _____
- _____

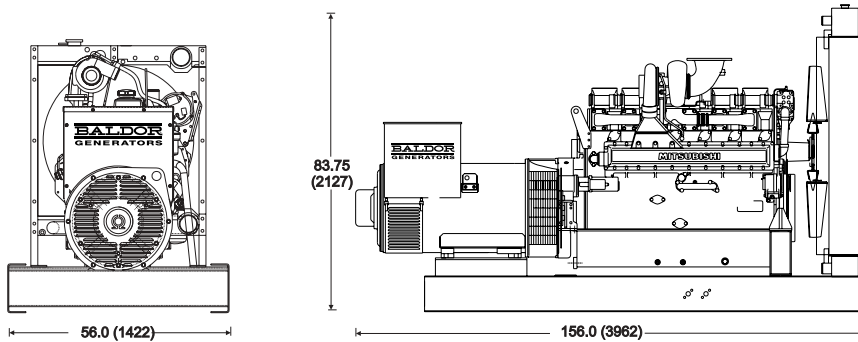

Dimensions – in (mm)

Weight – lbs. (Kg)
11,430 (3962)

Cubes (Approximate)
400 ft

*Open unit configuration,
accessories not included

Distributed by:

BALDOR GENERATORS

3815 Oregon Street • Oshkosh, WI 54902 • 1-800-872-7697 • Phone (920) 236-4200 • Fax (920) 236-4219
909 Perkins Drive • Mukwonago, WI 53149 • Phone (262) 363-1555 • Fax (262) 363-1556

World Headquarters

Baldor Electric Company • P.O. Box 2400 • Fort Smith, AR 72902-2400 U.S.A.
Phone (479) 646-4711 • Fax (479) 648-5792 • International Fax (479) 648-5895

www.baldor.com