

## Standby or Prime Power Features

- Heavy-duty Cummins 4-stroke gas engine, water-cooled
- Brushless synchronous alternators: four-pole construction, dynamically balanced
- Full featured microprocessor based controller: fully programmable for maximum flexibility
- Prototype tested and production tested
- UL2200 available – consult factory
- Optional weather-proof and sound attenuated enclosures available
- Full range of accessories and options available
- Heavy-duty construction for use in prime or standby application
- Manufactured in an ISO-9001 certified facility
- Backed by a world wide network of parts and service centers

## Gen Set Ratings

Baldor Genset Model	kW Rating Standby	kW Rating Prime	kW Rating Standby	kW Rating Prime	Voltage Hi-Wye	Voltage Low-Wye	Voltage Delta	Number of Leads	Phase	Hz	Power Factor
	Natural Gas 8.5:1		LP Gas 8.5:1								
IGLC750N-CA	750	675	N/A	N/A	480/277	240/139	N/A	12	3	60	0.8
IGLC750N-CB	750	675	N/A	N/A	440/254	220/127	N/A	12	3	60	0.8
IGLC750N-CB	750	675	N/A	N/A	416/240	208/120	N/A	12	3	60	0.8
IGLC750N-CB	750	675	N/A	N/A	380/220	N/A	N/A	12	3	60	0.8
IGLC750N-CH	750	675	N/A	N/A	600/347	N/A	N/A	12	3	60	0.8
IGLC750N-CXA	620	550	N/A	N/A	380/220	N/A	N/A	12	3	50	0.8

**NOTES:** For ratings and voltages not listed above refer to the Gen-Set Selector or consult factory  
 Standby ratings do not have an overload capability but can be used for the duration of the utility failure per ISO-3046, DIN6271 and BS5514  
 Prime (Unlimited Running Time) ratings are continuous per DIN 6271 and ISO-3046 with 10% overload capacity  
 Base Load (Continuous) ratings are continuous per DIN 6271, BS5514 and ISO-8528 with no sustained overload capacity  
 Consult factory for Base Load ratings  
 Altitude derate is 4% for each 1000 feet over 3000  
 Temperature derate is 1% for 10°F over 100°F ambient

# Controls Digital Control Module

## MEC2 Features

- Large Backlit LCD with alpha-numeric readout
- Microprocessor Based Design
- 16 programmable alarms/shutdowns set points
- 4 programmable inputs
- Alarm horn
- Not in Automatic Alarm
- Digital Three Phase Voltage and Current Monitoring
- Password Protected Front Panel Programming
- 4 Programmable Outputs
- Local Emergency Stop Switch
- Optional NFPA110 Level I

## Engine Protections

- Digital Oil Pressure Gauge
- Digital Water Temperature Gauge
- Digital Battery Voltmeter
- Overspeed Shutdown
- Emergency Stop Shutdown
- Loss of Speed Signal
- Overcrank Shutdown

## Designed To Meet/Exceed the Standards Below:

- UL 508
- UL 2200
- NFPA 70
- NFPA 110

## Engine Technical Data

Manufacturer	Cummins
Engine Model	GTA50-G1
Engine Type	4 cycle, 16 cylinder
Aspiration	Turbocharged and Aftercooled
Configuration	60 Degree Vee
Displacement - cu. in. (liters)	3067 (50.3)
Bore and Stroke - in. (mm)	6.25 x 6.25 (159 x 159)
Compression Ratio	8.5:1
Air Filter Type	Dry
Governor Type	Electronic
Governor Model	Woodward Flowtech
Injection Pump Type/Model	75mm
Frequency Regulation, steady state	+/- 0.25%
Frequency Regulation, no load to full load	Isochronous
Battery Voltage	24 VDC
Water Pump Type	Centrifugal
Coolant Cap. - radiator cooled - gals - liters	TBA
Coolant Capacity - engine only - gals - liters	162 (153)
Oil Pan Capacity - gals - liters	204 - 174 54 - 46
Rec'd Oil Type - SF/CC/CD-10°F to 90°F	10W-40

Engine Operational Values	English 50 Hz	Metric 50 Hz	English 60 Hz	Metric 60 Hz
Maximum ambient temperature - F° - C°	100	38	100	38
Heat rejected to coolant - Btu/min - kW	39,900	701	46,223	812
Heat rejected to aftercooler - Btu/min - kW	3,675	65	6,950	122
Max. power at rated rpm - bhp - kWm	958	715	1,150	858
Coolant flow - gpm - lpm	325	1,230	390	1,476
Exhaust temperature - F° - C° (maximum)	1,350	732	1,350	732
Exhaust flow - cfm - m <sub>3</sub> /min	7,164	3,381	8,266	3,902
Gas pressure required - in. H <sub>2</sub> O - mm H <sub>2</sub> O	10 -20	254 - 508	10 -20	254 - 508
Minimum pipe size @ engine - in. - mm	2	51	2	51
Normal oil pressure high - PSI - kPa	50-70	345-483	50-70	345-483

# Gen Set Technical Data

## Alternator Technical Data

Generator Frame	6	Voltage Regulation NL - FL	0.50%
Exciter	Brushless	Underspeed Protection	Standard
Cooling Fan	Cast alloy aluminum	Overexcitation Protection	Standard
Bearing	Single, double shielded	Overvoltage Protection	Standard
Connection Type	Reconnectable	Loss of Sensing Protection	Standard
Insulation Type	Class H	Overspeed	2250 RPM
Windings	100% copper	Standards	NEMA, IEC, IEEE, CSA, BS
Pitch	2/3	Phase Sequence	A(U), B(V), C(W)
Amortisseur Winding	Full	TIF (1960 Weightings)	<50
Voltage Regulator	MX321	Excitation System	PMG Standard

## Alternator Performance Data

	Model IGLC750N-CA	Model IGLC750N-CB	Model IGLC750N-CA
Temperature rise by resistance - °C (Stand-By)	150/40	150/40	150/40
Generator model number	HCI634G	HCI634H	HCI634G
Generator kW at 130/105/80°C over 40°C amb. (480 Volt , 60Hz)	740/675/588	850/770/680	740/675/588
SKVA output with 30% voltage dip max. 100% recovery at 60 Hz	2000	2300	2000
Maximum skva at 90% sustained voltage dip	Consult Factory	Consult Factory	Consult Factory
Subtransient reactance at voltage listed	18.00%	16.00%	18.00%
Line - line harmonic maximum total	3.50%	3.50%	3.50%

## Installation/Application Data

	English 50 Hz	Metric 50 Hz	English 60 Hz	Metric 60 Hz
<b>Ventilation requirements</b>				
a. Cooling airflow required - cfm - l/s (unit mounted radiator)	75,000	35,400	75,000	35,400
b. Combustion air required - cfm - l/s	1657	782	2,083	983
Total ventilation requirements - cfm - l/s (a. + b.)	76,657	36,182	77,083	36,383
Maximum cooling air restriction - in.H <sub>2</sub> O - mm.H <sub>2</sub> O	0.5	12.8	0.5	12.8
Minimum intake louver size (based on "free area") ft <sup>2</sup> - m <sup>2</sup>	75	7.0	75	7.0
a. Heat rejected to ambient, engine - Btu/min - kW	4,474	79	5,332	94
b. Heat rejected to ambient, generator - Btu/min - kW	4,068	71	4,883	86
Total heat rejection to ambient - Btu/min - kW (a. + b.)	8,542	150	10,215	179
<b>Exhaust system requirements</b>				
Exhaust gas flow - cfm - m <sup>3</sup> /min	7,164	3,381	8,266	3,902
Exhaust temperature (dry manifold) - °F - °C	1,350	732	1350	732
Maximum back pressure - in.hg - mm.hg (inclusive of silencer)	2	50.8	2	50.8
Exhaust outlet size - in. - mm	6	152.4	6	152.4
Emissions - HC - g/hp-hr	Consult Factory		1.91	
Emissions - CO - g/hp-hr	Consult Factory		17.3	
Emissions - NOX - g/hp-hr	Consult Factory		4.74	
<b>Fuel system requirements – see engine operational values for gas pressure requirements</b>				
Fuel consumption - 1/4 load - cu.ft/hr - BTU/Hp-hr (natural gas)	2,974	2,341	3,636	2,862
Fuel consumption - 1/2 load - cu.ft/hr - BTU/Hp-hr (natural gas)	5,453	4,291	6,666	5,246
Fuel consumption - 3/4 load - cu.ft/hr - BTU/Hp-hr (natural gas)	7,105	5,592	8,686	6,836
Fuel consumption - Full load - cu.ft/hr - BTU/Hp-hr (natural gas)	8,262	6,502	10,100	7,949
<i>Conversions: Cubic feet of Natural Gas/2.644 = Cubic Feet of LPG and Cubic Feet of LPG/8.533 = Gallons of LPG per hour - "estimated"</i>				
<b>Heat Exchanger Cooling system requirements</b>				
Minimum raw water (city water) flow - gpm/lps	Consult Factory	Consult Factory	Consult Factory	Consult Factory
Maximum supply water temperature - °F - °C	80°F	12.44°C	80°F	12.44°C
<b>Remote Cooling system requirements</b>				
Maximum coolant static head - ft. - m	60	18.3	60	18.3
Ventilation required (based on 25°F temp rise) - cfm - lps	18,982	333	22,700	399

# Accessories and Options

## Control Panel

- High Coolant Temp. Pre-alarm
- Low Oil Pressure Pre-alarm
- Alarm Horn with Switch
- Remote Start-Stop
- Remote Annunciator

## PER NFPA 110

- Run Relay
- Dry Contacts

## Engine Exhaust System

- Industrial Silencer
- Residential Silencer
- Critical Silencer
- Exhaust Flex
- Rain Cap
- \_\_\_\_\_

## Generator Accessories

- Main Line Circuit Breaker
- Shunt Trip
- Alternator Heater
- Field Circuit Breaker
- PMG
- \_\_\_\_\_

## Engine Electrical System

- Batteries
- Battery Rack
- Battery Cables
- Battery Charger - Automatic
- Battery Charger - Trickle
- \_\_\_\_\_

## Engine Fuel System

- Flexible Fuel Lines
- \_\_\_\_\_

## Miscellaneous

- Weather protective Enclosure
- Sound Attenuated Enclosure
- Vibration Isolators
- Coolant Heater
- \_\_\_\_\_

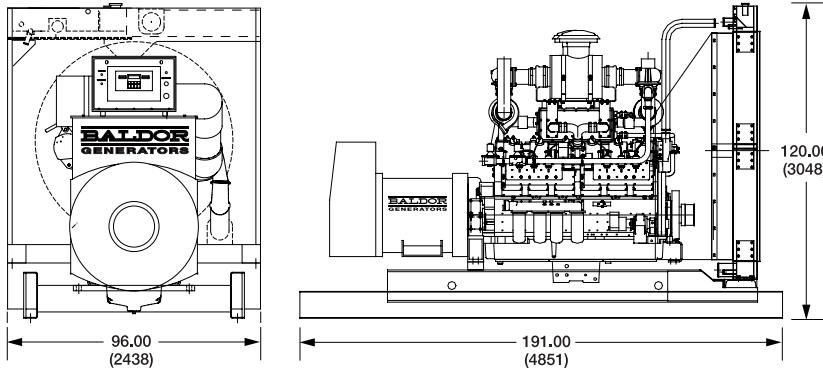

Dimensions – in (mm)

Weight – lbs. (Kg)  
20,314 (9214)

Cubes (Approximate)  
1275 ft

\*Open unit configuration,  
accessories not included

**Ratings – Standby Ratings:** Standby ratings are applicable for supplying emergency power for the duration of a utility power outage. Primary power to the installation is utility supplied. No overload capability for standby rating. Standby ratings in accordance with ISO 3046, BS55114, DIN 6271. **Continuous Power Rating:** Continuous power is the maximum power available for continuous duty. A 10% overload capacity is available for 1 hour out of 12 hours of operation. Prime Power ratings in accordance with ISO 3046, BS55114, DIN 6271. For additional information, please consult factory. Manufacture reserves the right to implement specifications or design changes without notice.

*Distributed by:*

**BALDOR**  
**GENERATORS**

3815 Oregon Street • Oshkosh, WI 54902 • 1-800-872-7697 • Phone (920) 236-4200 • Fax (920) 236-4219  
909 Perkins Drive • Mukwonago, WI 53149 • Phone (262) 363-1555 • Fax (262) 363-1556

World Headquarters

Baldor Electric Company • P.O. Box 2400 • Fort Smith, AR 72902-2400 U.S.A.  
Phone (479) 646-4711 • Fax (479) 648-5792 • International Fax (479) 648-5895

www.baldor.com